

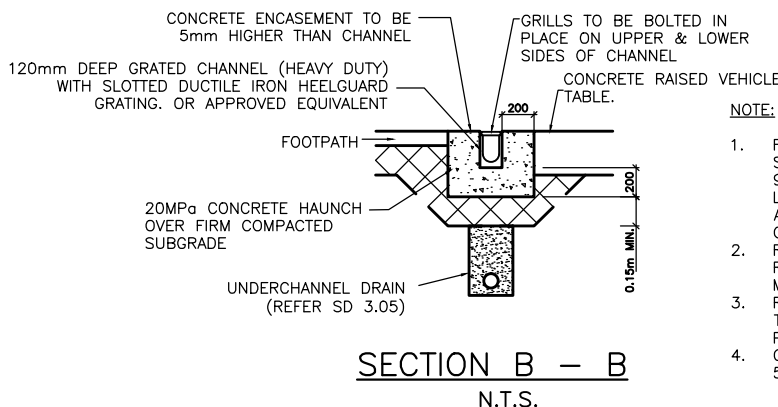

ADVANCE WARNING SIGNS ON  
APPROACHING SPEED-TABLE  
OR HUMPS

NOTE

1. PW-39 sign with supplementary as shown to be erected in advance of treatment on both sides of the carriageway facing approaching traffic

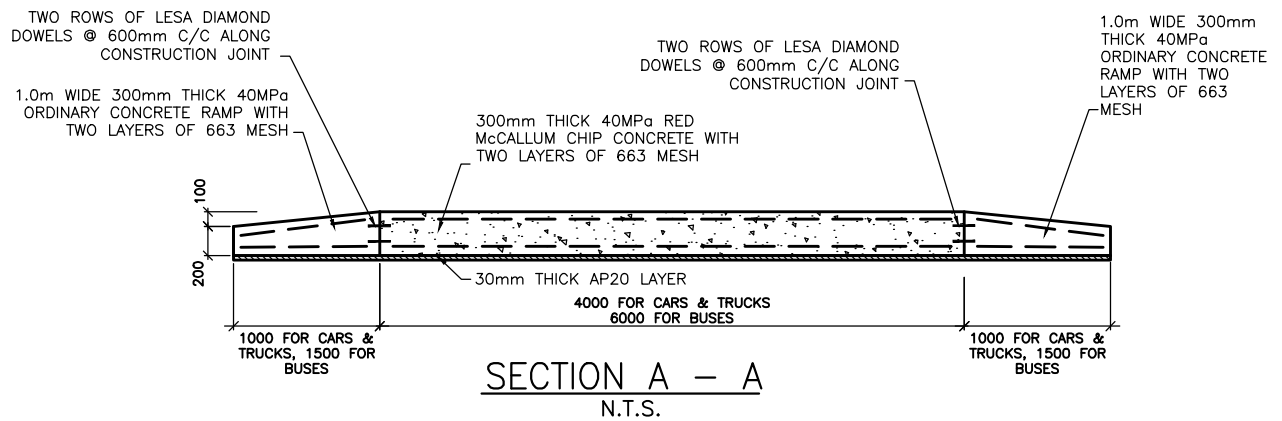
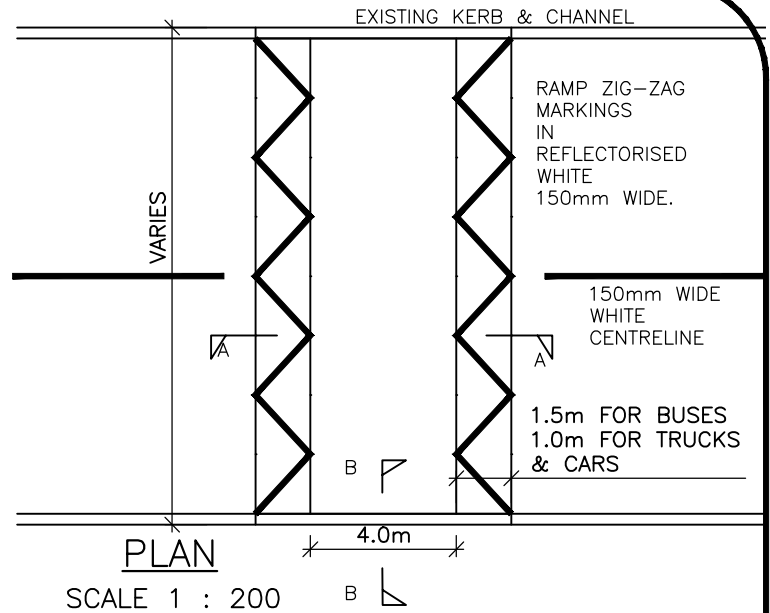

NOTE  
If a Zebra Crossing is combined with a speed-table Refer Pedestrian Planning and Design Guide Fig 15.15 for marking layout.

ENGINEERING  
STANDARDS MANUAL

ISSUE  
SEPTEMBER 2010

TYPICAL  
SPEEDTABLE

STANDARD DETAIL

SD3.19.1